



فرست اوتوماشن

Light Fittings

Series CZ0873 /2



Prodcuts Features

- The highest class of flameproof is up to IIC.
- Many patented technologies.
- It is convenient to be mounted and maintained.
- The degree of protection is up to IP66.
- International IECEx Approval, Europe union ATEX Approval.

Product Parameter

Product type:	Explosion-proof light fittings
Certification:	CCC IECEX ATEX
Application range (zones):	2G/Gb/zone 1; 2D/Db/zone 21
Min.ambient temperature:	-40°C
Max.ambient temperature:	+55°C
Degree of protection:	IP66
Rated voltage:	220V AC, 230V AC, 240V AC 230V/240V AC, 220V/230V/240V AC 50Hz, 60Hz



فرست اوتوماشن

Light Fittings

Series CZ0873 /2



Contact

info@first-automation.com.eg/ • 01101619222 – 01100200886 • <https://first-automation.com.eg/>



فرست اوتوماشن

Light Fittings

Series CZ0873 /2



It is easier to be wired by cage type terminal which is certified internationally.



The mounting ways of the explosion-proof platform light fittings C-90°



It is more convenient to be installed and maintained due to the design of ferrule suspension hook type, between the glass cover and the light fitting body;



The stainless steel mesh can be equipped as per the request



The mounting ways of the explosion-proof platform light fittings D-25°

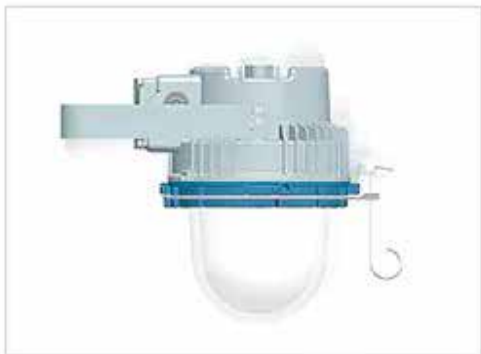

Bracket installation, multiple angle adjustment



Chain type. The light fitting can be equipped with the lamp shade as request



Installation of wall type lamp



فرست اوتوماشن

Light Fittings

Series CZ0873 / 2

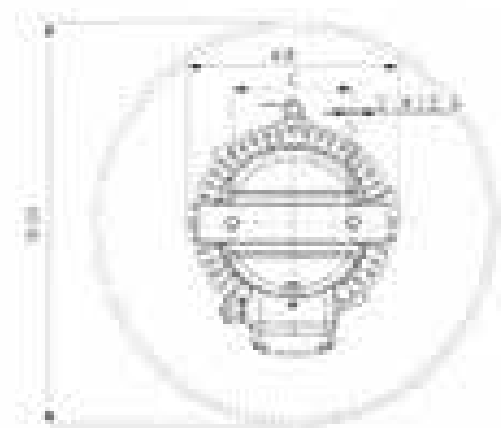
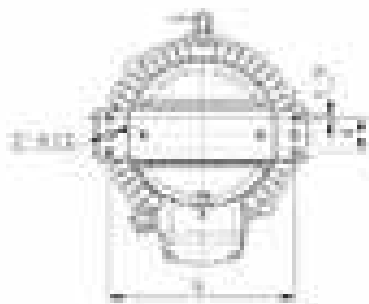
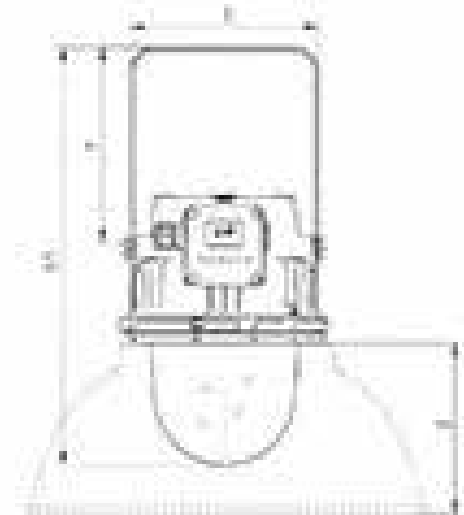
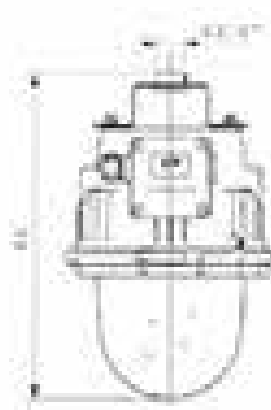
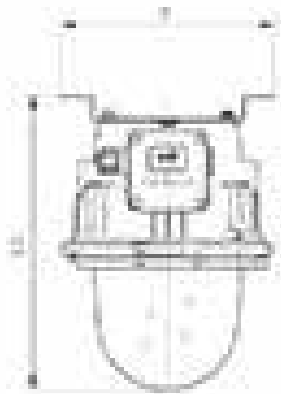
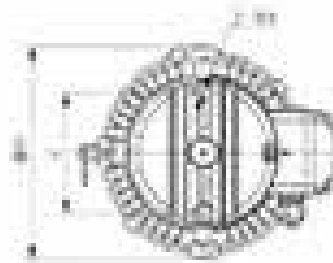
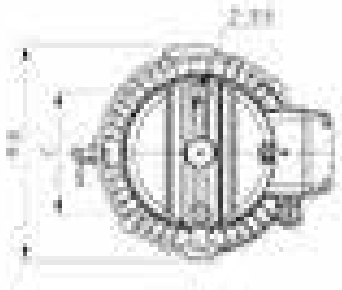
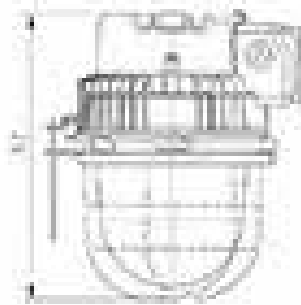
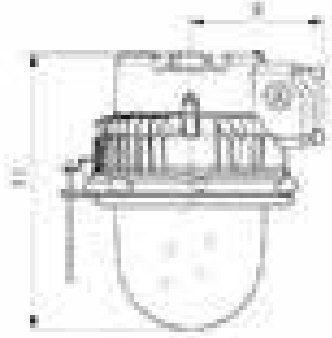

Unit:mm

Type	CZ0873/2	CZ0874/2
A1	317	422
A2	336	432
A3	346	450
A4	378	483
A5	400	530
B	153	180
C	140	169
D0	245	300
D01	475	643
E	220	268
F	229	265
G	220	240
H	250	270
I	40	40
J	200	200



فرست اوتوماشن

Light Fittings

Series CZ0873 / 2

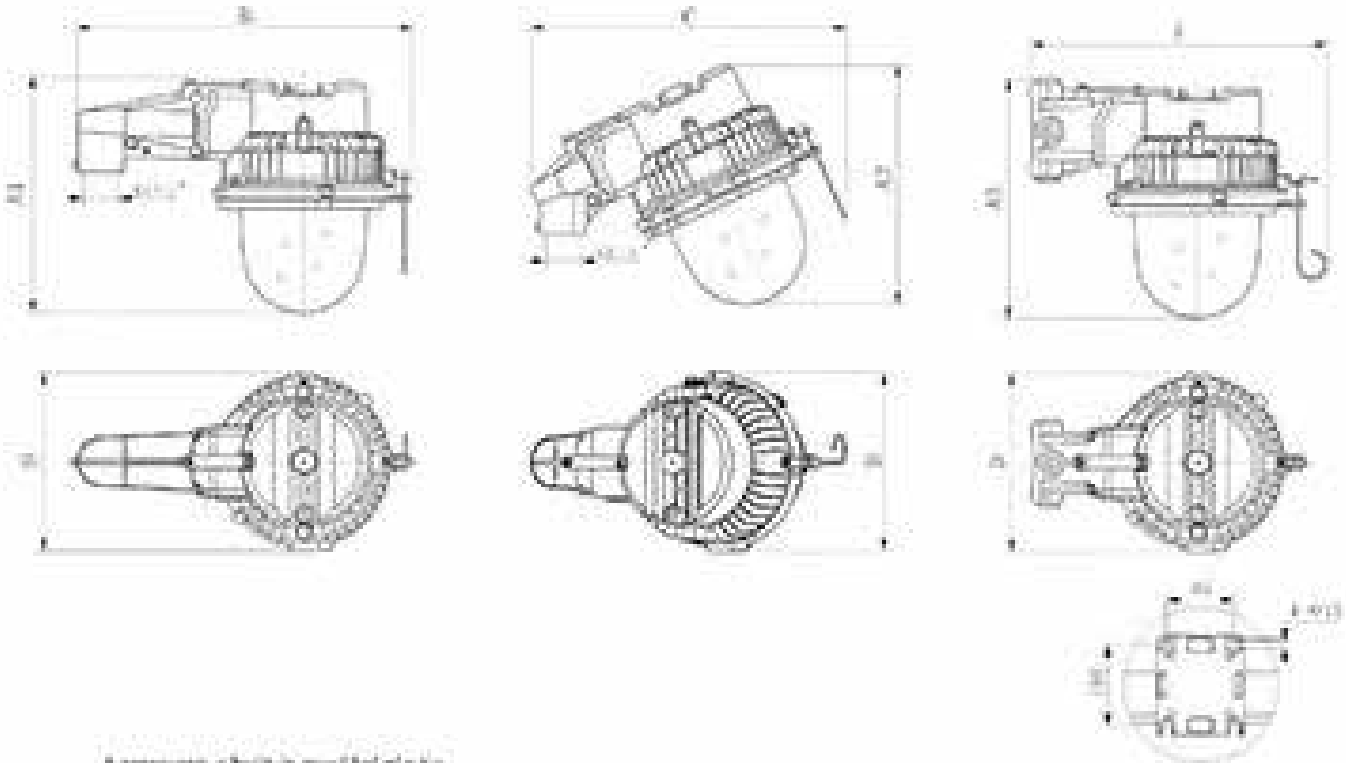

A represents a built-in moulded plastic
M25 cable gland

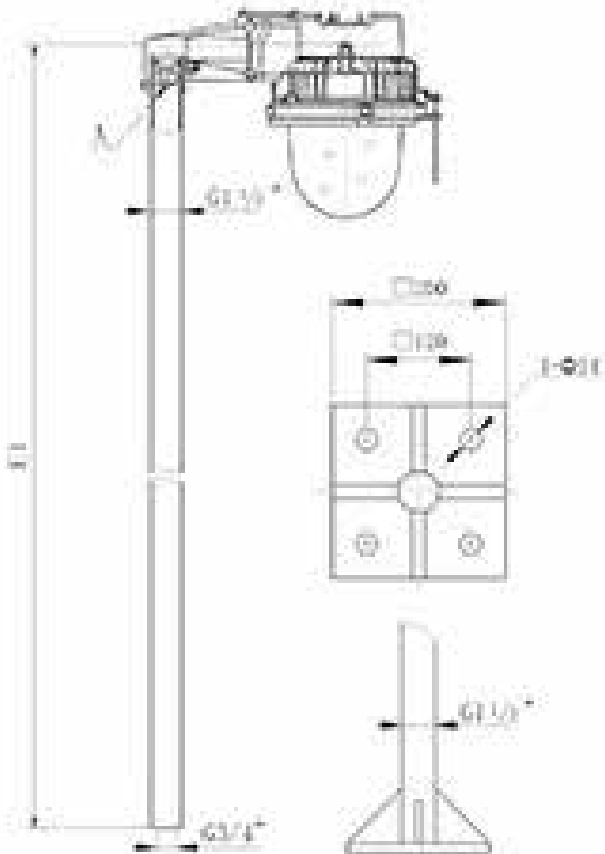

C — Lamp cap reserved in the angle of 90° Fanon type

Flange type

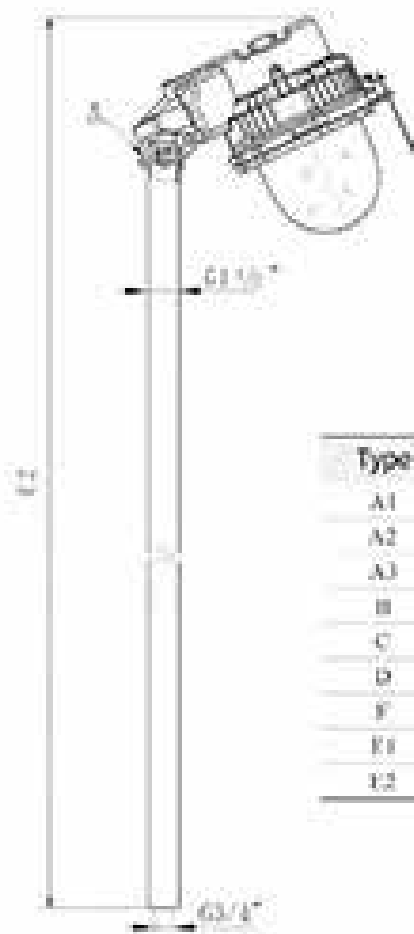

D — Lamp cap reserved in the angle of 27° Fanon type

Type	Unit: mm	
	CZ0873/2	CZ0874/2
A1	320	423
A2	320	433
A3	325	430
B	400	503
C	430	475
D	245	300
E	390	441
E1	2470	2470
E2	2500	2620



فرست اوتوماشن

Light Fittings

Series CZ0873/2



Illustration

Order No.



B

CZ0873/2□-LED25W17-□-B+□

CZ0873/2□-QL50W57-□-B+□



C

CZ0873/2□-JN45W57-□-B+□

CZ0873/2□-JN65W57-□-B+□



D

CZ0873/2□-J70W25-□-B+□

CZ0873/2□-J100W25-□-B+□

CZ0873/2□-J150W25-□-B+□



E

CZ0873/2□-N70W25-□-B+□

CZ0873/2□-N100W25-□-B+□

Contact

info@first-automation.com.eg/ • 01101619222 – 01100200886 • <https://first-automation.com.eg/>



فرست اوتوماشن

Light Fittings

Series CZ0873 /2



Optional Ex components



| CZ0220 Series Plastic stopping plugs, the reducer



| CZ0221 Metal cable glands



| CZ0220 Series Plastic cable glands, stopping plugs



| CZ0226 Increased safety cable glands



| CZ0527, CZ1725/27 Increased safety breathing, drainage valve



| CZ0227 Increased safety metal cable glands



| CZ1725/1C Metal cable glands



| CZ1725/2A Metal cable glands



| CZ1725/3A Metal stopping plug



| CZ1725/1A Metal cable glands



| CZ1725/4A The reducer



| CZ1725/1B Metal cable glands



فرست اوتوماشن

Light Fittings

Series CZ0873 /2



Accessories



D8722/1, D8722/2

Ceiling bracket

D8722/1: Accessories for bracket type lamp, for CZ0873/4

D8722/2: Accessories for bracket type lamp, for CZ0874/4

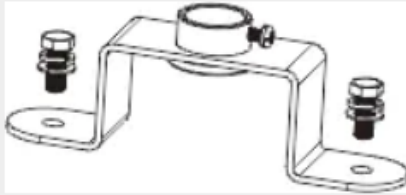

D8702/1, D8702/2

Mounting bracket of pendant type

D8702/1: Accessories for bracket type lamp, for CZ0873/4

D8702/2: Accessories for bracket type lamp, for CZ0874/4



D623

Chain type accessories(500mm)

Accessories for bracket type lamp, M8 bolt, made from steel with zinc-coated surface



فرست اوتوماشن

Light Fittings

Series CZ0873 /2



Accessories



D8701/1, D8701/2

Mounting bracket

D8701/1: Accessories for bracket type lamp, for CZ0873/4

D8701/2: Accessories for bracket type lamp, for CZ0874/4



D732

G3/4"-300mm Straight pipe

Accessories for bracket type, galvanized steel pipe material and powder coated surface



D8725

Lamp pole of fence type

Accessories for platform type lamp, G1 1/2 " galvanized steel pipe material and powder coated surface

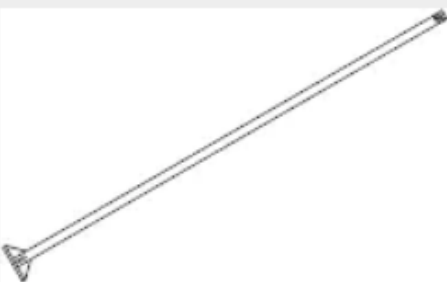

D8726

Accessories for platform type lamp, G1 1/2 " galvanized steel pipe material and powder coated surface