



فرست اوتوماشن

# Emergency Light

Series CZ0875/0876



## Prodcuts Features

- Full plastic explosion-proof LED linear light fittings are available in mounting: ceiling type, chain type, pendant type, wall type or clamp type.
- Full plastic explosion-proof LED linear light fittings (pole mounting) are available in mounting: platform fence type, platform flange type, or wall type.
- Explosion-proof isolation switch and explosion-proof fuse are optional.
- Emergency versions have indicator indicating fault if there is, charging and discharging.
- The structural design is never distortion and its protection degree is up to IP66.
- IECEx and ATEX certified.





فرست اوتوماشن

# Emergency Light

Series CZ0875/0876



## Product Parameter

<b>Product type:</b>	Full plastic explosion-proof emergency LED linear light fittings (Pole Mounting)
<b>Certification:</b>	CCC IECEX ATEX
<b>Application range (zones):</b>	3G/Gc/zone 2; 2D/Db/zone 21
<b>Min.ambient temperature:</b>	T5: -25°C T4: -25°C( CZ0875 )( CZ0876 )
<b>Max.ambient temperature:</b>	T5: +40°C T4: +55°C( CZ0876 )T4: +50°C( CZ0875 )
<b>Degree of protection:</b>	IP66 ( IP64 with breather CZ0527 )
<b>Rated voltage:</b>	AC100 ~ 250V 50/60Hz
<b>Color temperature:</b>	5700K
<b>Color rendering index:</b>	Ra≥80
<b>Power factor:</b>	$\lambda > 0.95$



فرست اوتوماشن

# Emergency Light

Series CZ0875/0876

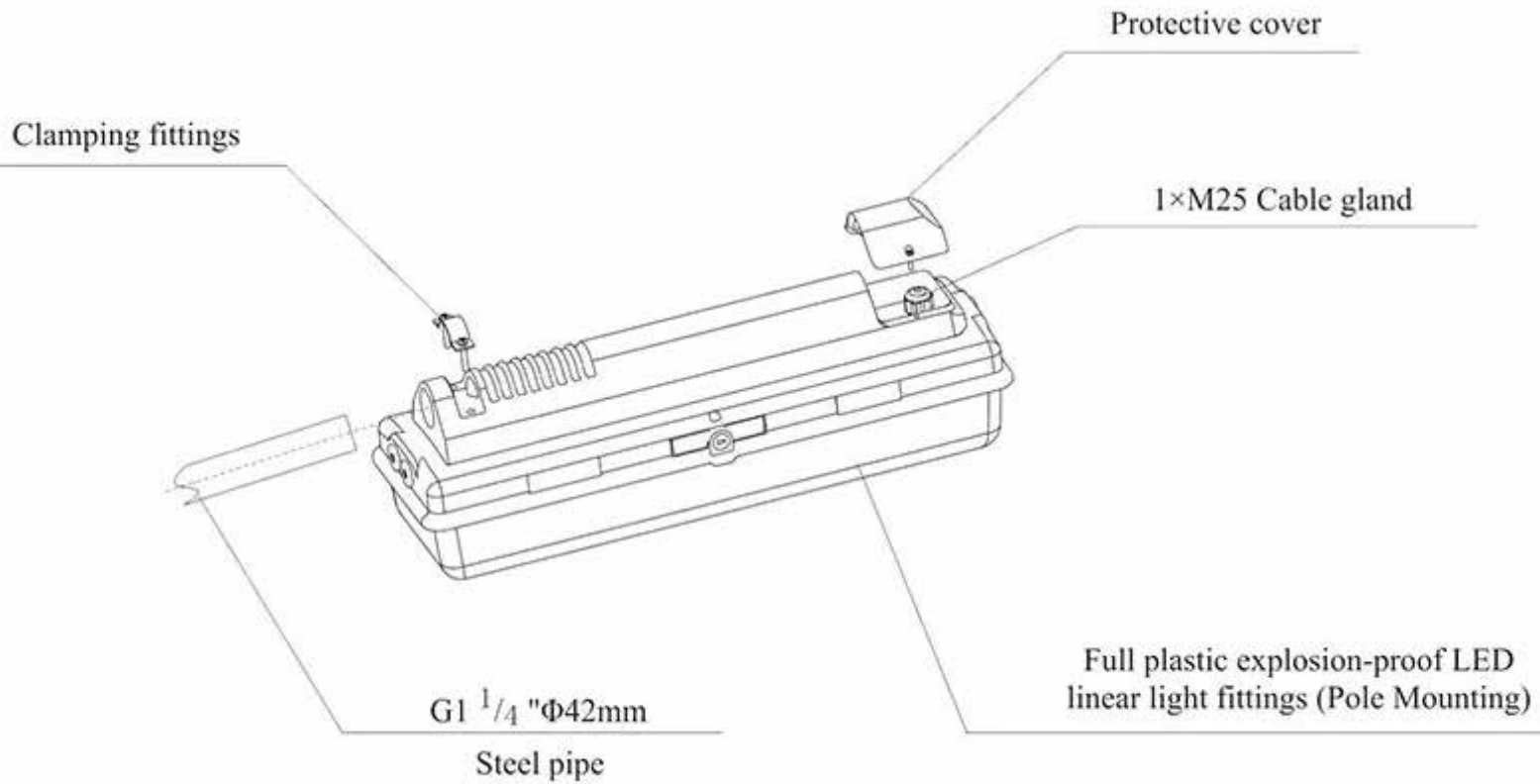

Contact

info@first-automation.com.eg/ • 01101619222 – 01100200886 • <https://first-automation.com.eg/>



فرست اوتوماشن

# Emergency Light

Series CZ0875/0876



CZ0876/2xLED 30W□

Full plastic explosion-proof LED linear light fittings

- ① LED light source module
- ② Diffuser (optional)
- ④ Explosion-proof power supply module
- ⑦ Explosion-proof isolation switch

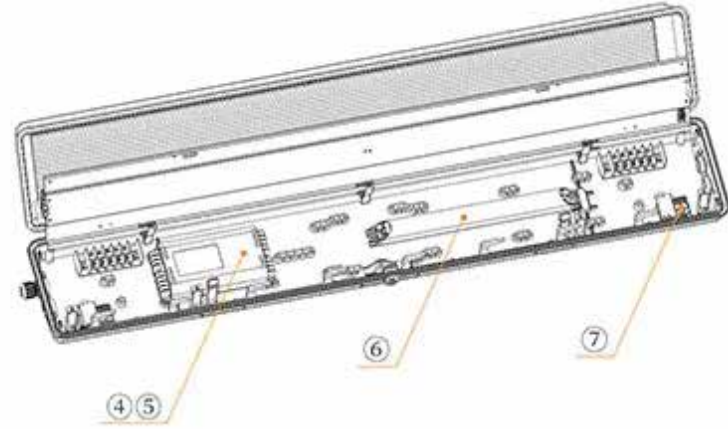

CZ0876/2xLED 30W□ YJ

Full plastic explosion-proof LED (emergency) linear light fittings

- ① LED light source module
- ② Diffuser (optional)
- ③ Explosion-proof Indicator light
- ⑤ Explosion-proof inverter
- ⑥ Explosion-proof battery
- ⑦ Explosion-proof isolation switch



فرست اوتوماشن

# Emergency Light

Series CZ0875/0876

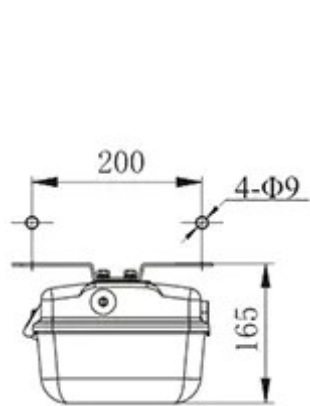

Ceiling type

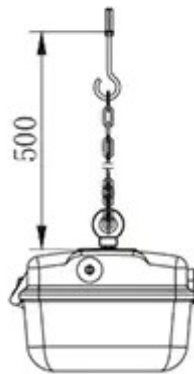

Chain type

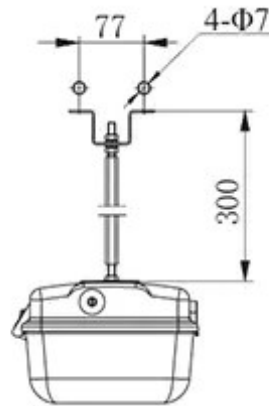

Pendant type

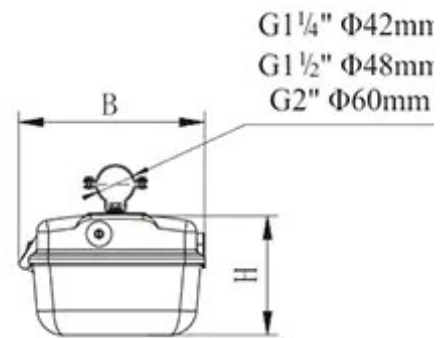

Clamp type

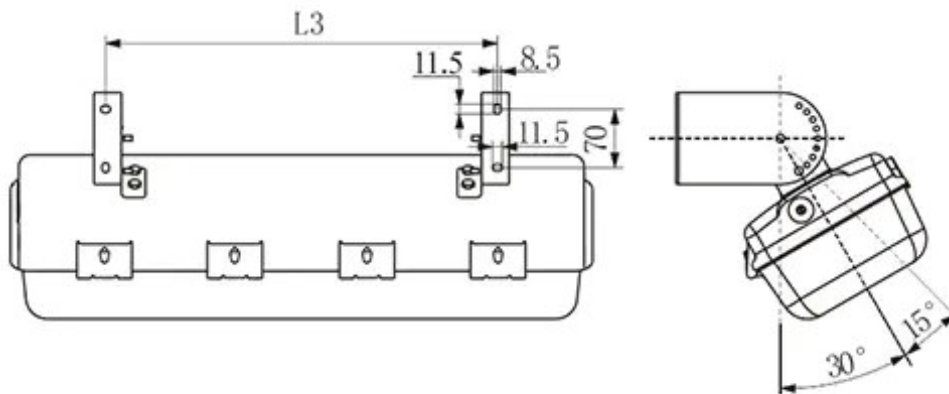

Adjustable mounting bracket



فرست اوتوماشن

# Emergency Light

Series CZ0875/0876



单位:mm

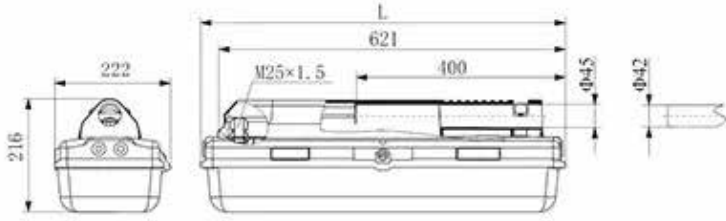

全塑防爆(应急)条形灯(杆式安装)

型号	L	L1	L2	H1	H2
CZ0865	698	850	815	2635	2645
CZ0866	1310	1440	1405	2740	2750

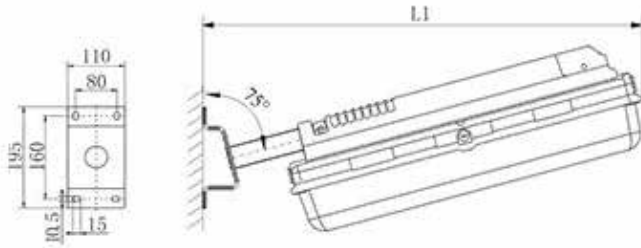

D8739 杆式墙壁安装支架

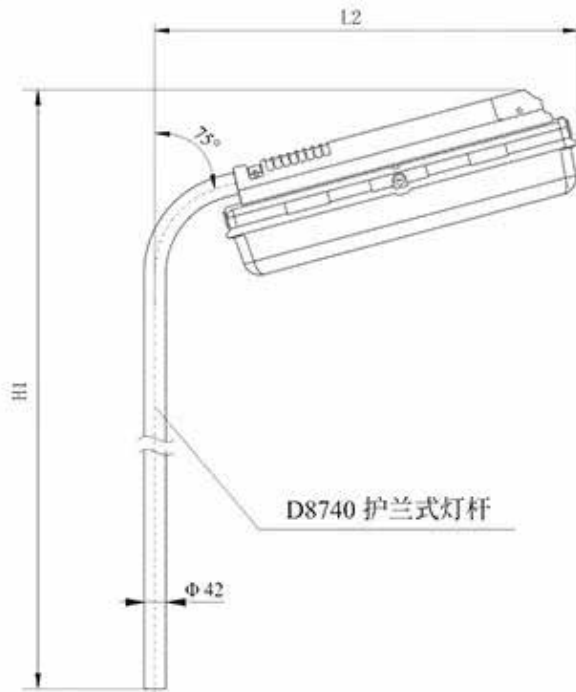

D8740 护栏式灯杆

护栏式安装

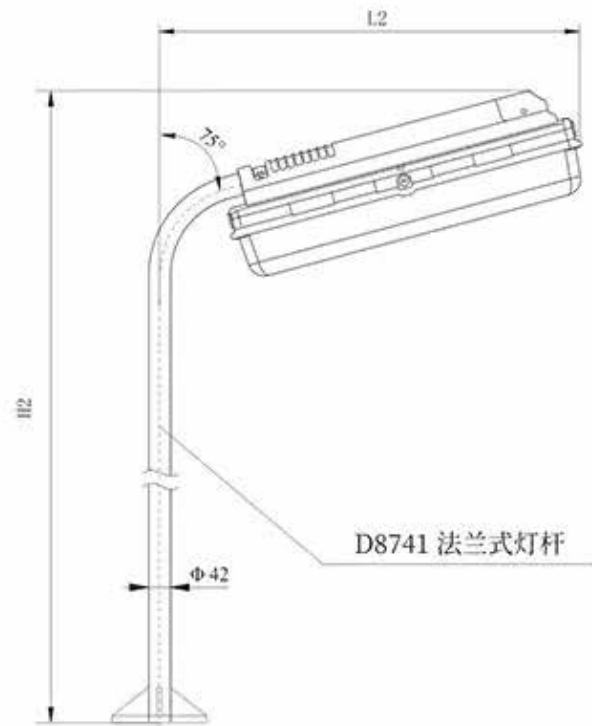

D8741 法兰式灯杆

法兰式安装



فرست اوتوماشن

# Emergency Light

Series CZ0875/0876



单位 : mm

型号	CZ0865	CZ0866
L	698	1310
L1	400	800
L2	550	1100
L3	470	870
L4	800	1300
B	222	222
H	145	145
H1	2510	2510
H2	2500	2500
H3	1050	1050

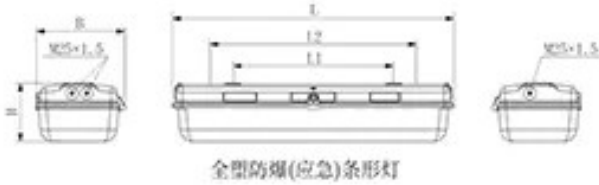

全塑防爆(应急)条形灯

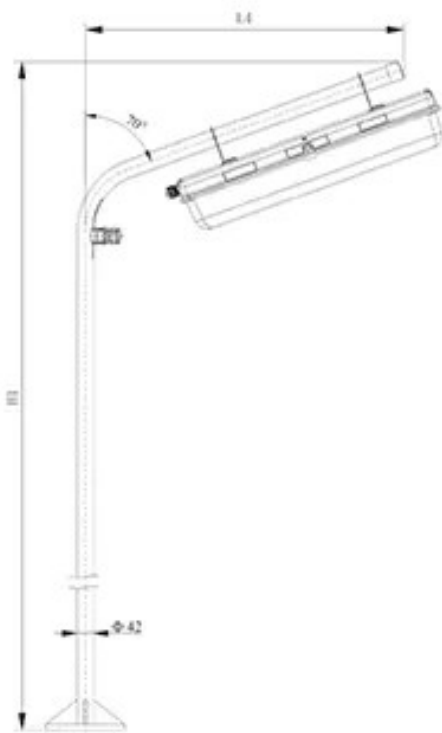

法兰式安装

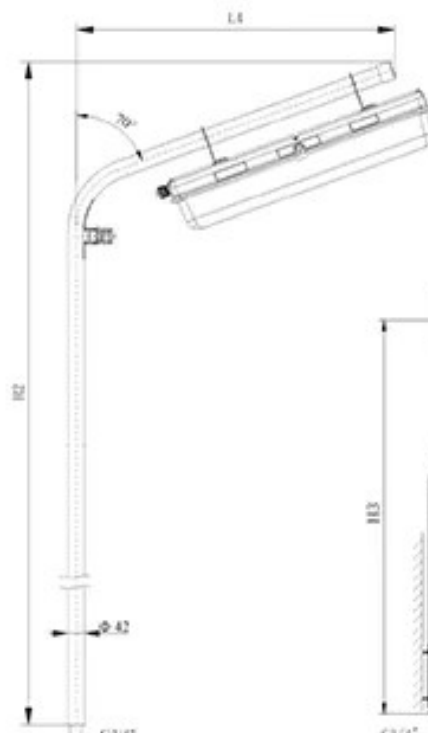

护栏式安装

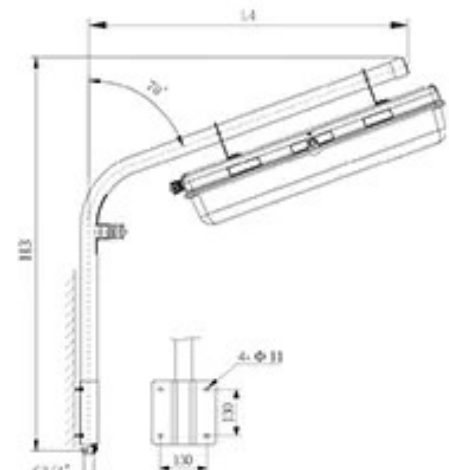

壁式安装



护栏式安装

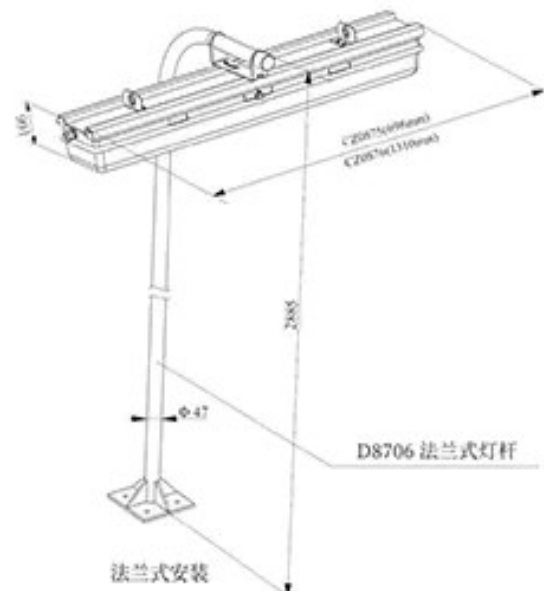

法兰式安装

Contact

info@first-automation.com.eg/ • 01101619222 – 01100200886 • https://first-automation.com.eg/



فرست اوتوماشن

# Emergency Light

Series CZ0875/0876



Illustration	Order No.
 <p>CZ0875, CZ0876 Full plastic explosion-proof LED linear light fittings</p>	CZ0875 / 1×LED30W1-□-B+□
	CZ0875 / 1×LED30W2-□-B+□
	CZ0876 / 2×LED30W1-□-B+□
	CZ0876 / 2×LED30W2-□-B+□
 <p>CZ0875, CZ0876 Full plastic explosion-proof LED linear light fittings (Pole Mounting)</p>	CZ0875/1×LED30W1-□-PM+□
	CZ0875/1×LED30W2-□-PM+□
	CZ0876/2×LED30W1-□-PM+□
	CZ0876/2×LED30W2-□-PM+□





فرست اوتوماشن

# Emergency Light

Series CZ0875/0876



Illustration	Order No.
 <p>CZ0875, CZ0876 Full plastic explosion-proof emergency LED linear light fittings</p>	CZ0875 / 1×LED30W1-YJ-□-B+□
	CZ0875 / 1×LED30W2-YJ-□-B+□
	CZ0876 / 2×LED30W1-YJ-□-B+□
	CZ0876 / 2×LED30W2-YJ-□-B+□
 <p>CZ0875, CZ0876 Full plastic explosion-proof emergency LED linear light fittings (Pole Mounting)</p>	CZ0875 / 1×LED30W1-YJ-□-PM+□
	CZ0875 / 1×LED30W2-YJ-□-PM+□
	CZ0876 / 2×LED30W1-YJ-□-PM+□
	CZ0876 / 2×LED30W2-YJ-□-PM+□



فرست اوتوماشن

# Emergency Light

Series CZ0875/0876



## Optional Ex components



| CZ0220 Series Plastic stopping plugs, the reducer



| CZ0221 Metal cable glands



| CZ0220 Series Plastic cable glands, stopping plugs



| CZ0226 Increased safety cable glands



| CZ0527, CZ1725/27 Increased safety breathing, drainage valve



| CZ0227 Increased safety metal cable glands



| CZ1725/1C Metal cable glands



| CZ1725/2A Metal cable glands



| CZ1725/3A Metal stopping plug



| CZ1725/1A Metal cable glands



| CZ1725/4A The reducer



| CZ1725/1B Metal cable glands



فرست اوتوماشن

# Emergency Light

Series CZ0875/0876



## Accessories

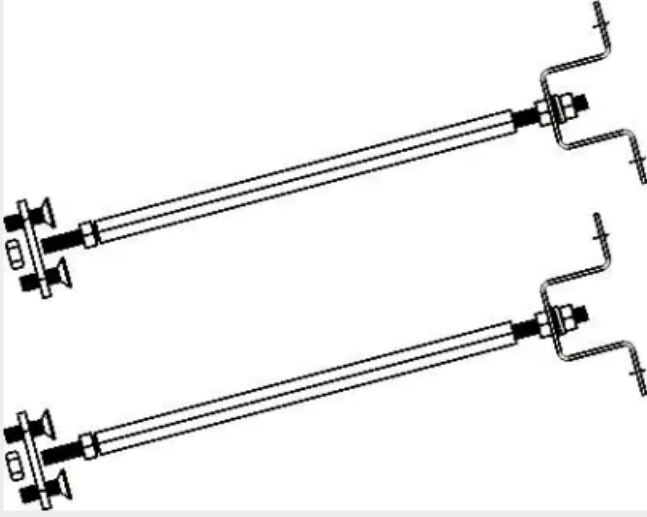

D622

Accessories for  
pendant type



D623

Accessories for  
chain type



فرست اوتوماشن

# Emergency Light

Series CZ0875/0876



## Accessories

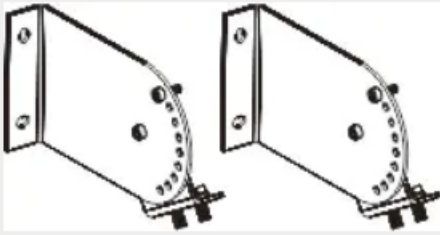

D8738

Adjustable  
mounting bracket

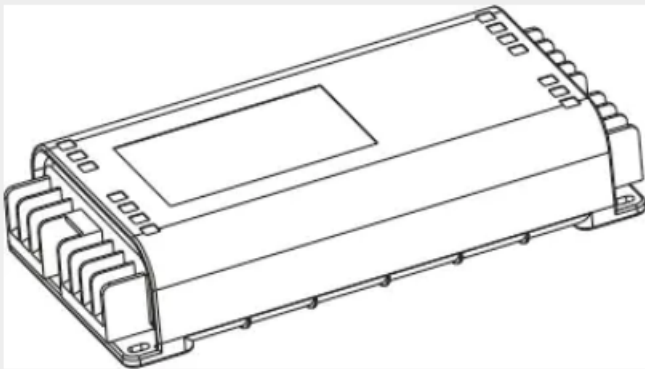

CZ1618/58-2xLED30W

Type of protection: II 2G Ex eb q IIC Gb  
Normal power: 2x30W, emergency power: 2x10W,  
Used for 2xLED30W emergency LED linear light  
fittings  
AC100~250V



فرست اوتوماشن

# Emergency Light

Series CZ0875/0876



## Accessories

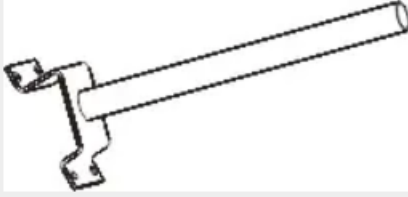

D8739

Wall mounting  
bracket of pole type

Use for pole mounting linear light fittings



D8705, D8706

Lamp pole of fence type: D8705  
Lamp pole of flange type: D8706

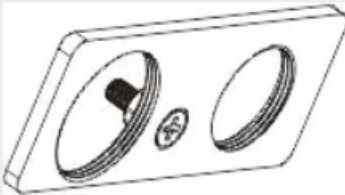

D8714/2-M25

Metal earthing nut 2-M25x1.5



فرست اوتوماشن

# Emergency Light

Series CZ0875/0876



## Accessories

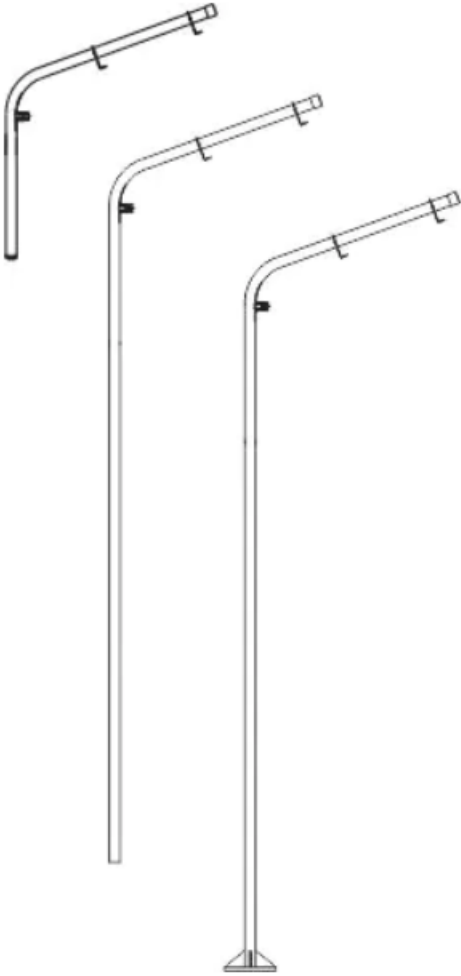

D8709, D8710, D8711

Lamp pole of wall type:

D8709/1A Used for CZ0865 LED linear light fittings

D8709/2A Used for CZ0866 LED linear light fittings

Lamp pole of fence type:

D8710/1A Used for CZ0865 LED linear light fittings

D8710/2A Used for CZ0866 LED linear light fittings

Lamp pole of flange type:

D8711/1A Used for CZ0865 LED linear light fittings

D8711/2A Used for CZ0866 LED linear light fittings



فرست اوتوماشن

# Emergency Light

Series CZ0875/0876



## Accessories



D8740, D8741

Lamp pole of fence type:  
D8740 Use for pole mounting linear  
light fittings  
Lamp pole of flange type:  
D8741 Use for pole mounting linear  
light fittings



D8742/1, D8742/2

Mounting bracket  
D8742/1 Used for CZ0865 LED linear light fittings  
D8742/2 Used for CZ0866 LED linear light fittings

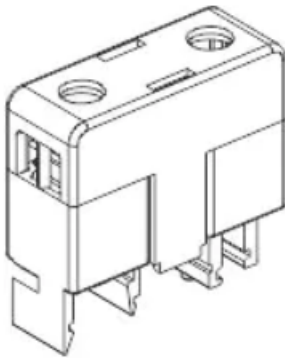

CZ0804

Explosion-proof fuse module  
(optional fittings)  
CZ0804/T0.8A  
CZ0804/T1.25A  
CZ0804/T6.3A



فرست اوتوماشن

# Emergency Light

Series CZ0875/0876



## Accessories

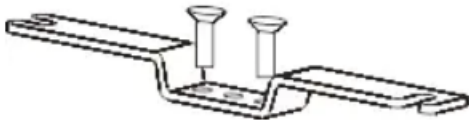
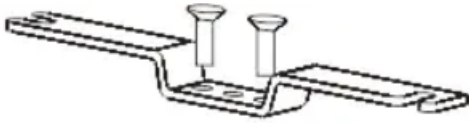

D621, D621/304

Support for ceiling type

Steel, Stainless steel

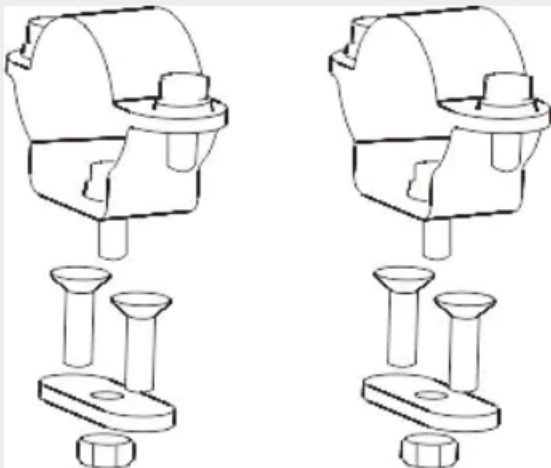

J200, J200/304; J300, J300/304; J400, J400/304

Accessories for clamp  
type M8 bolt mounting

J200: G1 1/4"Φ42mm Steel

J200/304: G1 1/4"Φ42mm Stainless steel

J300: G1 1/2"Φ48mm Steel

J300/304: G1 1/2"Φ48mm Stainless steel

J400: G2"Φ60mm Steel

J400/304: G2"Φ60mm Stainless steel





فرست اوتوماشن

# Emergency Light

Series CZ0875/0876



## Accessories

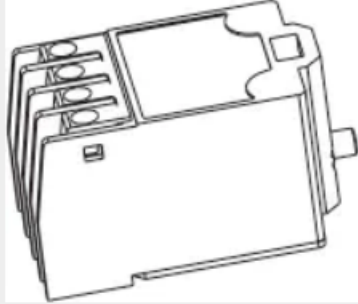

CZ0207-1

Explosion-proof isolation  
switch module  
(optional fittings)

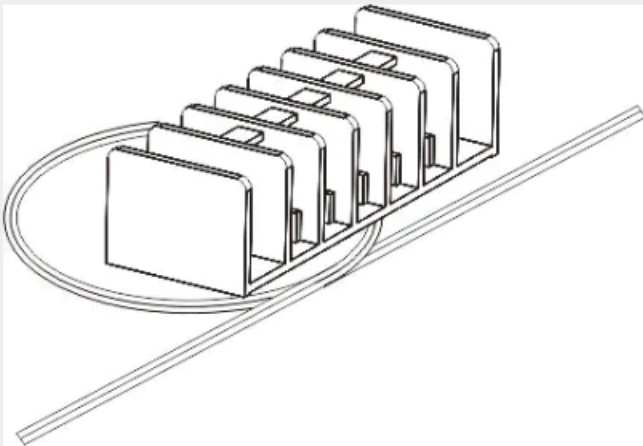

305

With conductor terminal board

305/21: 1×LED 30W

305/22: 2×LED 30W

3P terminal, Conductor 3×2.5mm<sup>2</sup>  
max16A, L1+N+PE

305/31: 1×LED 30W

305/32: 2×LED 30W

4P terminal, Conductor 4×2.5mm<sup>2</sup>  
max16A, L1+L2+N+PE



فرست اوتوماشن

# Emergency Light

Series CZ0875/0876



## Accessories

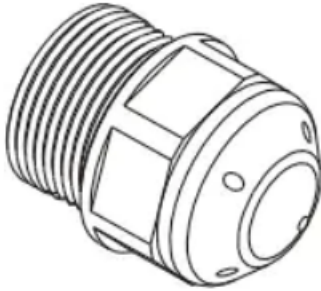

CZ0527 2515 e001

Increased safety breathing,  
drainage valve

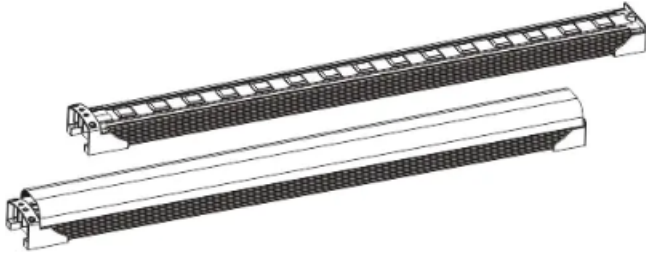

CZ1718/11

Explosion-proof LED light source module

CZ1718/11-LED30W1:

Without diffuser

Power: 30W / 3851 lm / 5700K

CZ1718/11-LED30W2

With diffuser

Power: 30W / 3366 lm / 5700K



فرست اوتوماشن

# Emergency Light

Series CZ0875/0876



## Accessories

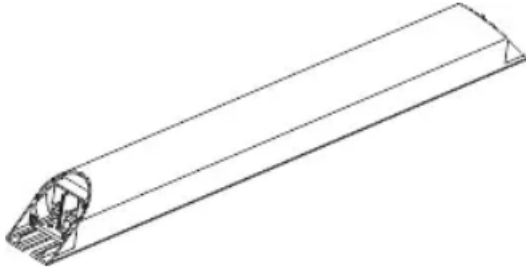

CZ0819/3.0Ah 7.2V

CZ0819/4.5Ah 7.2V

Explosion-proof battery module

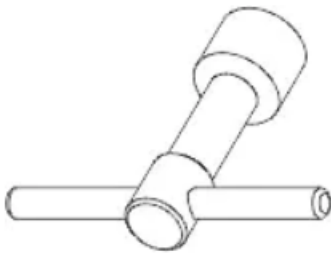

D601

M8/SW13 Sleeve spanner

Used for CZ0865、CZ0866,  
Material: Fine quality steel with galvanized surface

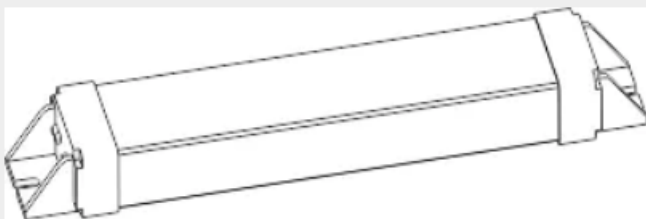

CZ1718/57-2×LED30W

Explosion-proof power supply module

Power: 2×30W,  
Used for 2×LED30W linear light fittings  
AC100~250V

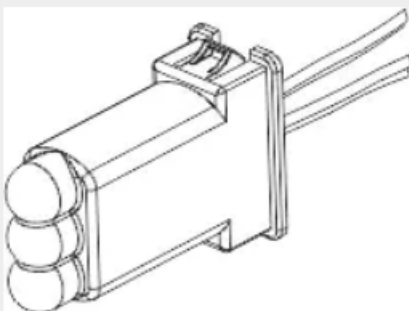

CZ0802/1

Explosion-proof emergency  
indicator module

Three colors for LED: red, yellow, green